

# LOADING AND SECURING CARGO ON/TO VEHICLES

In accordance with EN 12195-1:2010

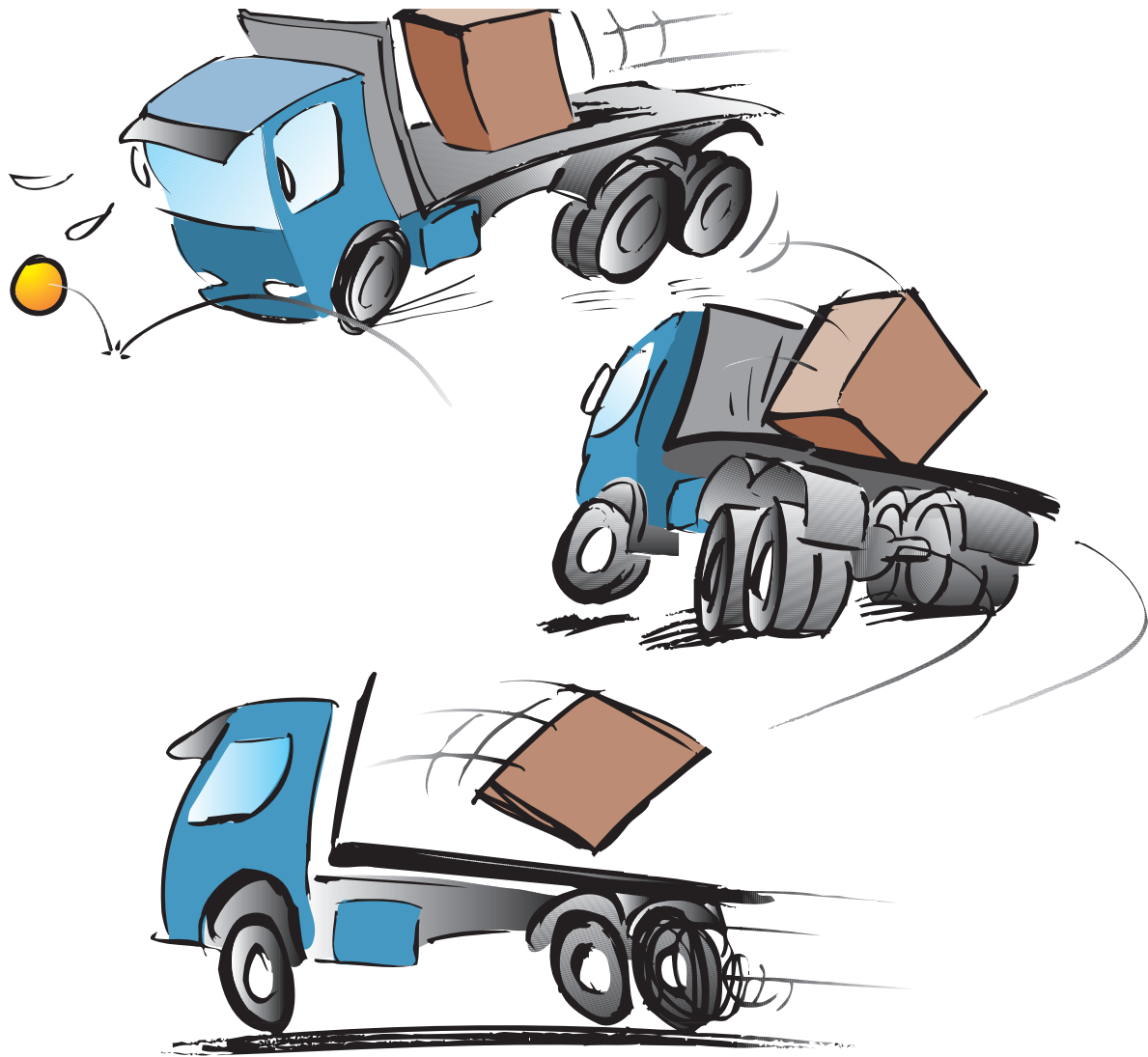

A Handbook for students

# SECURING CARGO TO VEHICLES

## A Handbook for students

### Presentation of the partnership and the roles of the individual partners behind the project;

TYA (The Vocational Training and Working Environment Council of the Transport Trades), Sweden	Contractor
VTenL (Vakopleiding Transport en Logistiek), the Netherlands	Partner
TUR (Transport Training Board of Denmark), Denmark	Partner
TÜV-Akademie Rheinland, Germany	Partner
AFT/IFTIM, France	Partner

**Text: Stefan Reimers, TYA and Nils Östergren, Skriv Om**  
**Illustrations: Hans Sandqvist, Bildinformation i Älvsjö AB**

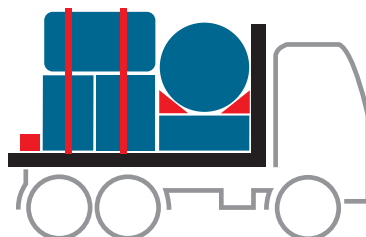

<b>Introduction</b>	<b>5</b>
Consequences.....	6
<b>Responsibility</b>	<b>10</b>
Laws and regulations.....	10
<b>Strain</b>	<b>12</b>
Strain and tension to the cargo.....	13
<b>Load carriers CTU's</b>	<b>18</b>
<b>Equipment</b>	<b>21</b>
Vehicles .....	21
<b>Loading</b>	<b>31</b>
To load vehicles is to build vehicles.....	31
Many ways of overloading .....	32
International laws and regulations .....	33
Vehicle documents.....	33
Consignment note, Bill of lading, Waybill.....	33
National waybill.....	35
Load and distribute .....	35
Order of loading and distribution.....	36
<b>Methods and principles</b>	<b>37</b>
Blocking .....	38
Lashing .....	39
Calculating number of lashings.....	43
<b>Loads</b>	<b>47</b>
General cargo .....	47
Crates and roll-containers.....	49
Bulk cargo .....	49
Long goods .....	50
Liquids and gases under pressure.....	51
Barrels .....	51
Dangerous goods .....	52
Perishable goods.....	52



# INTRODUCTION



The cargo is not to blame if it moves away from the platform in a curve, deceleration or acceleration. In all its innocence the cargo obeys the laws of nature.

For centuries man has learned to master many laws of nature. This has been achieved by knowledge, tools and machines. Now we can fly to the moon, change heart and lungs, even split atoms.

Despite this, one badly secured load of cargo after the other continues to cause devastating traffic accidents.

It is obvious the person who does the loading not always knows, wants or is permitted to do the necessary work to secure the load.

You, who want but does not know, will get good help from this manual.

You, who want but is not permitted, can show this manual to your contractor and ask or argue for better facilities and possibilities.

You, who do not want to, although you can and may, can stop reading here.

The argument, that there may be carriers, drivers and helpers who do not want to make secure transports, may seem unfair and insulting. But be sure, if a serious accident occurs, someone will – during sleepless nights – continuously ask himself:

Did I have sufficient knowledge of securing cargo?

Did I get sufficient material to do a proper securing?

Would a greater awareness of the risks for accidents and a stronger will *have saved* lives?

The best intentions on earth cannot prevent accidents to people. This also applies to transportation. However there is plenty of reliable equipment for securing loads and simple rules of thumb about the forces affecting the cargo – easily accessible tools to those who want to do a good job and reduce risks.

The transport of goods and cargo in Europe is increasing in volume and is more and more coordinated. Consequently everybody working in transport needs to have corresponding and improved knowledge about cargo securing.

The carriers of today are often specialized. In consequence only a few kinds of goods and types of vehicles are present at the same workplace. This obviously limits the need of knowledge of cargo securing for certain transport workers.

Despite this there is no excuse for inadequate basic knowledge in elementary securing during transport of most goods on the majority of load carriers.

The reasons are several:

- Carriers get new customers and goods to handle.
- Transport workers change their place of work or employer more often.
- The transport industry is by nature full of unforeseen situations, also in regular cargo securing work.
- The specialisation in transport work does not yet include all parts of a country, companies and goods.
- Last but not least : As modern and advanced as the transport system of today is, you still risk to be confronted by the one customer who wants to transport a delicate, antique, 200 pound heavy floor clock, not to be laid horizontal, and with its centre of gravity at the top. Shall a true transport worker, with his honour at stake, be able to say ‘no’ to such a request?

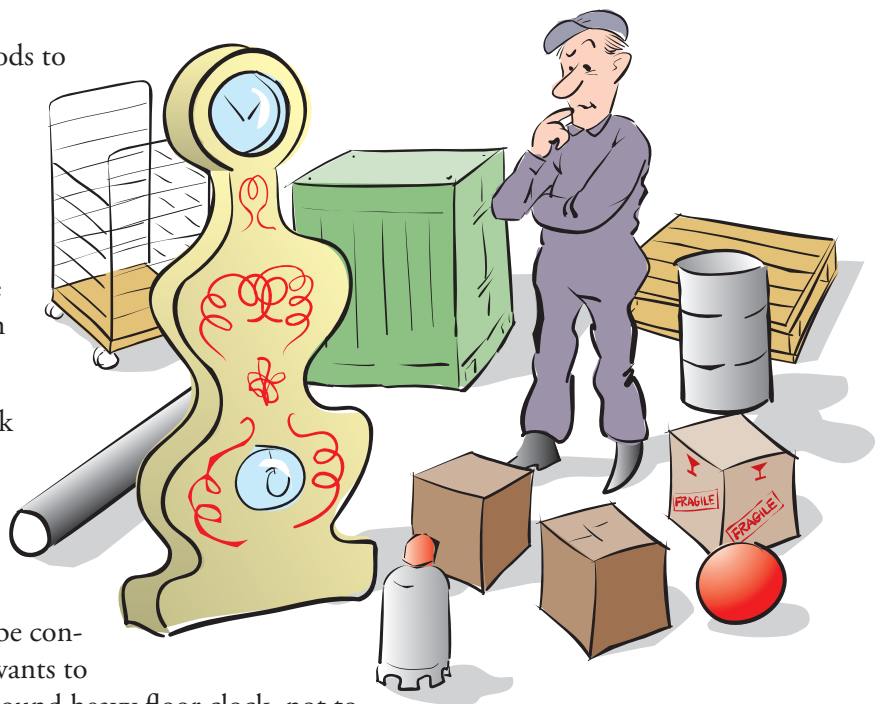

## **Consequences**

To load securely in the modern transport system does not only call for a profound knowledge. Without the farsightedness, the fantasy and the creativity that many persons in the industry possess, transport accidents would certainly be many times higher.

The causes of damage during transport are most often incorrect or careless handling, incorrect or damaged equipment, improper loading and securing. The consequences can be classified in different groups:

## Damage to people and environment



*Trailer that has lost some of its load of pallets in the second layer.*



*Each pallet weighed 600 kilos, packed with paper-sheets.*



*An unlucky road use at the wrong place at the wrong time.*

The number of fatal accidents varies from country to country, but they have in common that the consequences cannot be measured in hard cash. The same goes in general for the damage to the environment. In both cases the effects of the accident are spread like rings on the water; relatives to both killed and injured persons may get their lives ruined and damage to the environment can change the conditions of life for people as well as animals in a large area.



## Damage to vehicles and load carriers



*Wonder if I will be in time for the next load?*

Damage to vehicles is more common than one imagines. Many of them are difficult to discover, for instance virtually invisible weaknesses at securing points, which in turn can cause other, very serious, damage.

## Damage to the cargo



*One of how many a year?*

Most damage during transport occurs to the cargo itself. Such damage costs the cargo owners in Europe many millions a year.

## Economic consequences



*Anyone waiting for this Just In Time transport at the line in the car factory?*

Damage to cargo often causes delay, economic loss, decline in customer relations, cost of reloading etc.



## “Combined and chain” consequences.



*Goodwill for the export industry?*

Some consequences of incorrect cargo securing is not in proportion to the basic cause of the misfortune. In sea transport there are many examples of relatively small defects in cargo securing which, when combined with other factors, have sunk whole ships. It may have started in one single trailer. Some cargo has come loose and under increasing rough seas put the trailer in motion. Soon the swaying trailer has pulled the nearby load carriers with it and finally the cargo has shifted and the ship developed a list.

Buyers of cargo transport today demand very high quality of delivery. Many who place orders have logistic systems which are based on the precondition that as little goods as possible shall be stored as short a time as possible. Consequently, the importance of the cargo or goods arriving at the time agreed and in the condition it was when received for loading increases. This is one of the reasons it is getting more common that carriers are certified – approved after checking.

For him who wants to take care of his future in the transport industry the importance of reliable cargo securing ought to have been illustrated by this.

# RESPONSIBILITY

## *Laws and regulations*



Every EU-country has its own legislation for road traffic with regulations regarding securing cargo. Although the language and phrasing differ in the text, the intentions are the same and can be summarized as follows:

The cargo must be secured in such a way that accidents are prevented i.e. the cargo must be placed and secured so it cannot

- cause danger to persons
- cause damage to property
- drag behind or fall off the vehicle
- cause disturbing dust or similar inconvenience
- affect the safe conveyance of the vehicle in a negative way
- make unnecessary noise.

Beside this some countries have detailed instructions showing how the securing must be done. When goods are transported (nationally or internationally) in or through countries with this type of instructions, the driver is responsible for the securing and can be fined if the securing is not in compliance with national instructions. The transport unit will also be stopped from further movement until the cargo is properly secured.

When containers, trailers and similar units are transferred from road vehicles to railway or seagoing vessels the responsibility for securing in the load carrier remains with the loader or the person who delivers the unit for further transport. Railway Companies and Shipping Companies are responsible only for securing the load carrier to the railway wagon or the ship. This applies to all European countries.

# STRAIN

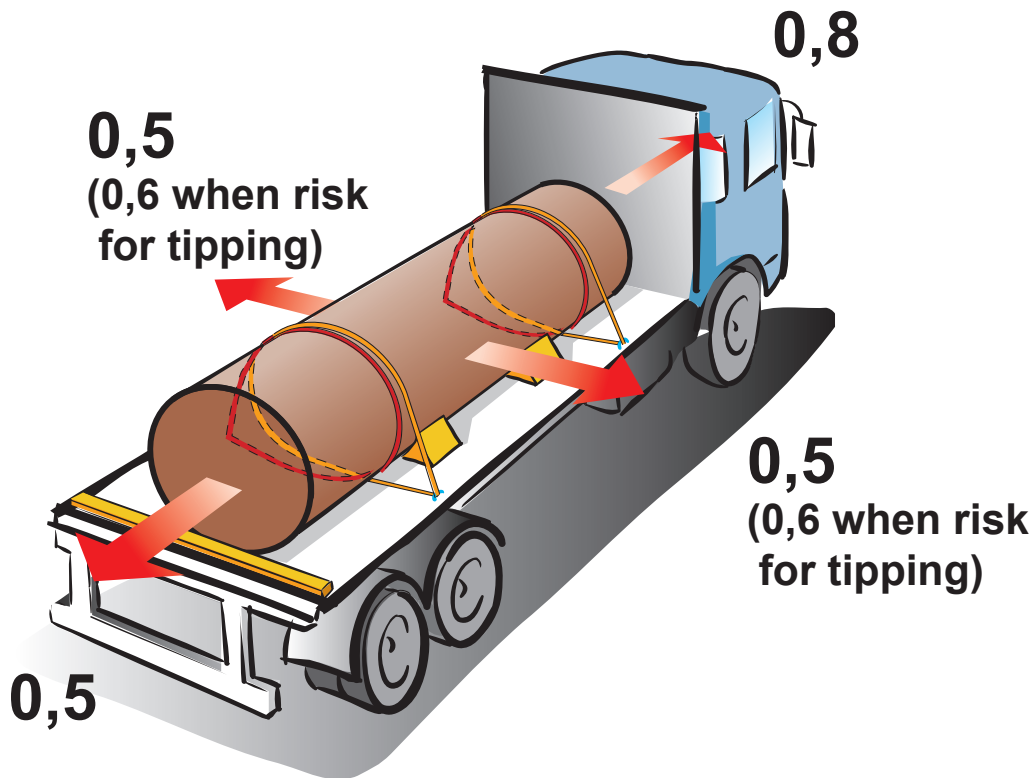

A vehicle in motion is under the influence of various forces in different directions, the faster the vehicle moves, the stronger they are. These forces, the position of the cargo and its centre of gravity influence the possibility of driving the vehicle safely.

Safety can be achieved through help from the guidelines, principles and ideas that apply to cargo securing. Nothing peculiar, really: All is based on elementary laws of nature, easy to understand and use. It is about, among other things, acceleration, centrifugal force and deceleration. These forces are expressed in metres per second raised to the second power, but in the daily work of transport it is often sufficient to note the weight of the cargo and the following rule of thumb:

- **The cargo securing must carry:**
  - 0,8 of the cargo weight forwards,**
  - 0,5 of the cargo weight sideways and backwards and**
  - 0,6 of the cargo weight sideways if there is risk for tipping.**

The methods to be presented here meet the demand of these rules only as long as the vehicle is still on the road. The forces the cargo suffers when the vehicle falls over or collides often become so strong that eventually only the Most High is able to influence the outcome.

## Strain and tension to the cargo

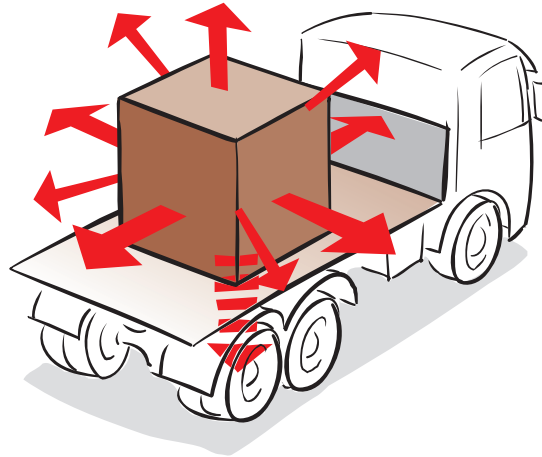

One can say that transport workers are struggling against the wind. According to the totally informal law of “the bloody nastiness of things” the cargo always wants to do the opposite; it wants to remain when you drive away (accelerating force), go to the side when you turn (centrifugal force) and continue ahead when you want it to stop (deceleration force). How strong this “will” is depends on the speed of the vehicle, the weight of the cargo (mass), how easily the cargo can slide on the surface (friction) and on its tendency to tip over (centre of gravity).

So the most important factors are:

- Gravity
- Acceleration
- Centrifugal force
- Deceleration
- Vibration forces
- Weight
- Friction
- Centre of gravity
- Cargo dimension

## Gravity

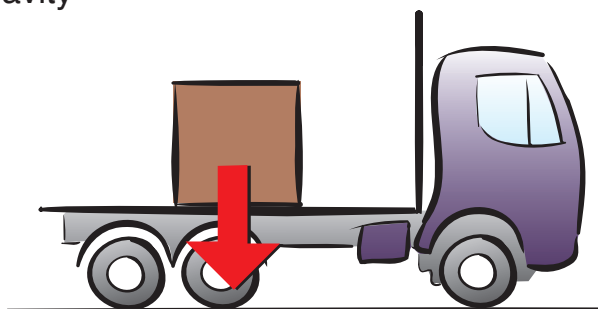

A piece of goods standing still on a flat surface is exposed to a force that acts (wants to pull) straight down to the centre of the earth. This force is called gravity and is of the same value as the weight of the piece of goods. If the goods weigh 1 ton, the downward force is equal to 1 ton.

## Acceleration

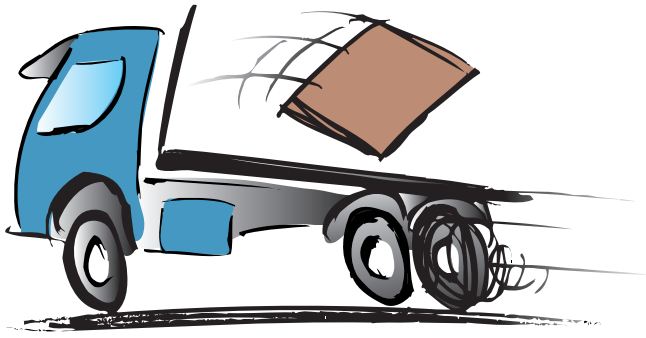

*If the goods weigh 1 ton the securing backwards must bear 0,5 tons (500 Kg).*

When the vehicle starts and increases its speed forwards the cargo strives to move backwards. The force that acts on the cargo corresponds at the most to one half of its weight.

## Centrifugal force

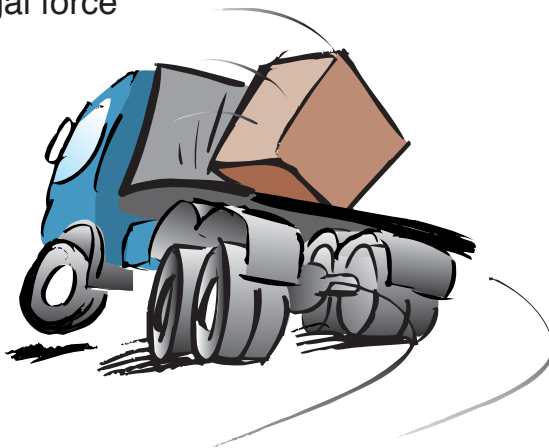

*If the goods weigh 1 ton the securing sideways must bear 0,5 ton (500 Kg) or 0,6 ton when there is risk for tipping.*

When the vehicle turns the cargo wants to continue in the initial direction. The force that then acts on the cargo and drives it to the side of the vehicle corresponds at the most to one half of its weight.

## Deceleration

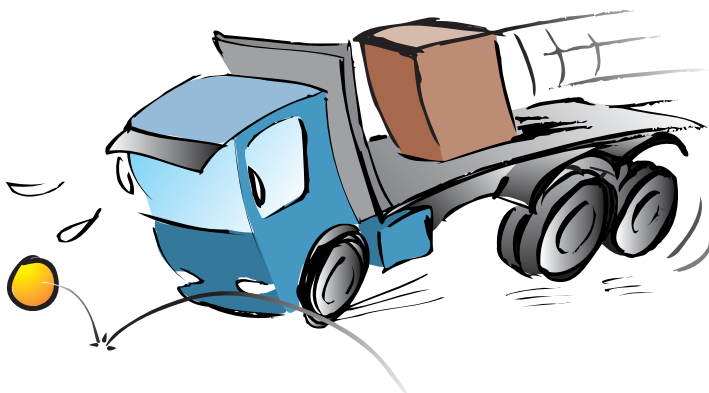

*If the goods weigh 1 ton the securing forwards must bear 0,8 ton (800 Kg).*

When the vehicle slows down the cargo strives to move forward. The force that then acts on the cargo corresponds at the most to its full weight.



## Intermodal transport

Railroad combined transport

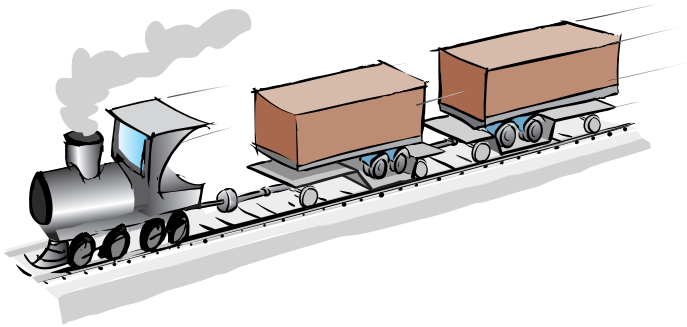

Forwards	Backwards	Sideways*
1,0	1,0	0,5

Sea transport



Sea Area	Forwards*	Backwards*	Sideways
A	0,3	0,3	0,5
B	0,3	0,3	0,7
C	0,4	0,4	0,8

\* variations in downwards forces can occur.

Intermodal transport signifies when a load carrier – trailer or swap body – is transported by two or more of the following means of transport: lorry, railway or ship. Since the different means of transport create different forces that affect the cargo it is very important that the load is secured for the whole transport from the beginning. The tables show how much of the load weight (the value x the weight) the securing must carry.

## Vibration



Vibration creates small but many power shocks to the cargo. If it continues long enough the cargo can “walk” fatally far away.

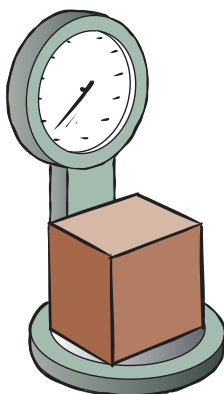

## Weight

The weight of the cargo influences the magnitude of the forces it is exposed to during the transport. Because of this the weight, in principle, decides how strong the securing must be

Weight can also be called mass and is in these circumstances expressed in kilos or tons.

## Friction

The roughness between the cargo and the surface underneath – friction – might be the best friend of the transport worker in the task of securing cargo. Friction counteracts the forces the cargo is exposed to during the transport. This means, for instance, when the number of lashings on top of a unit is to be calculated, a strong friction may save some webbing.

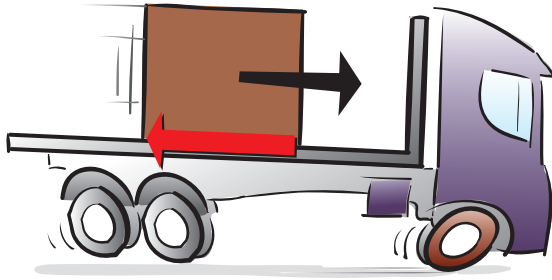

Contact between different materials has different friction coefficients (the friction coefficient is often written  $\mu$  and pronounced mju). The higher the coefficient of friction the more the friction is able to hold a load in place. As a rule, a dry surface has higher friction than a wet or greased one.

There are two different values of friction of importance when you secure the cargo.

- Static friction – the highest friction measured until the unit starts to slide
- Sliding friction – the lowest friction measured when the unit is sliding

In this manual we use static friction and will show how it can be measured by a slope/inclination test.

### *Slope/inclination test*

A unit is placed on a flatbed that is slowly tilted. When the unit starts to slide the tilting is stopped and the angle between the flatbed and the horizontal level (flat ground) is measured.

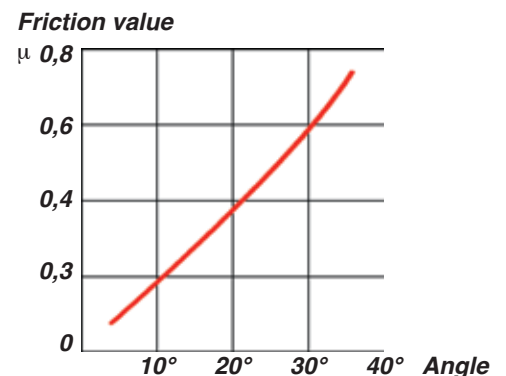

**Ex. If you have read an angle of 22° you see that  $\mu$  ( the friction coefficient ) is = 0,4.**

The angle read off is then used in the table where you see what friction coefficient the actual combination of materials has.

## Centre of gravity

The centre of gravity of a unit/package is crucial to how it must be secured against tipping over. If it is particularly heavy in the upper part and has a smaller part of its weight at the bottom, it is obviously more disposed to tip over than otherwise. This also applies if the centre of gravity is close to any of the sides of the package.

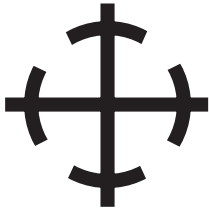

Symbol for centre of gravity.

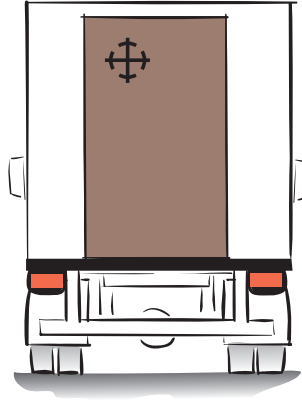

It happens that producers or senders mark the cargo with a symbol showing where the centre of gravity is situated, but there is no such rule. If the symbol is missing it does not actually indicate the package is homogeneous – has its centre of gravity in the middle.

To decide if a risk of tipping during road transport is at hand in any case when the weight is evenly distributed in the load - the centre of gravity is judged to be in the centre – follow this procedure:

### *Forwards:*

If the height (H) of the load is not more than the length (L), it need not be secured for tipping forwards.

### *Backwards:*

If the height (H) of the load is not more than double its length (L) against the surface underneath, it does not have to be secured for tipping backwards.

### *Sideways:*

If the height (H) of the load is not more than double its breadth (B) against the surface underneath, it does not have to be secured for tipping sideways.

### **RULE OF THUMB:**

- If the cargo is not higher than it is long, there is no risk of tipping forwards.
- If the cargo is not more than double as high as its length or breadth there is no risk of tipping backwards or to the sides.

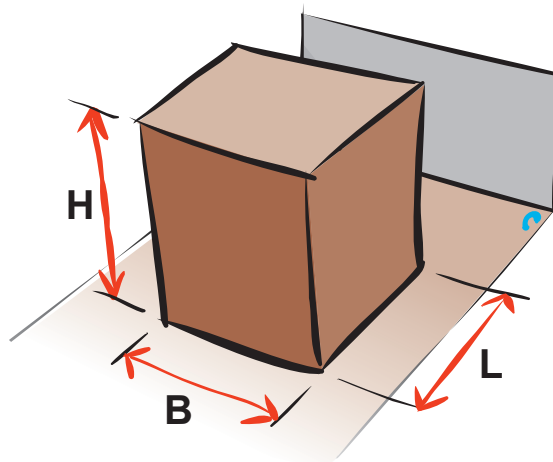

# LOAD CARRIERS CTU's

There are a great variety of transport units This manual will limit itself to securing methods on the following load carriers.

## Lorry

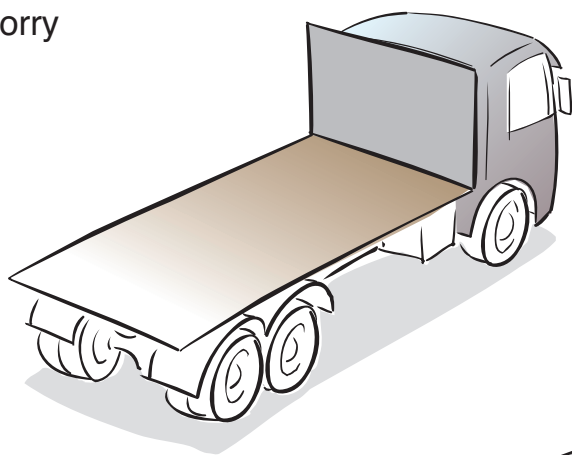

*Flat-bed platform with headboard*

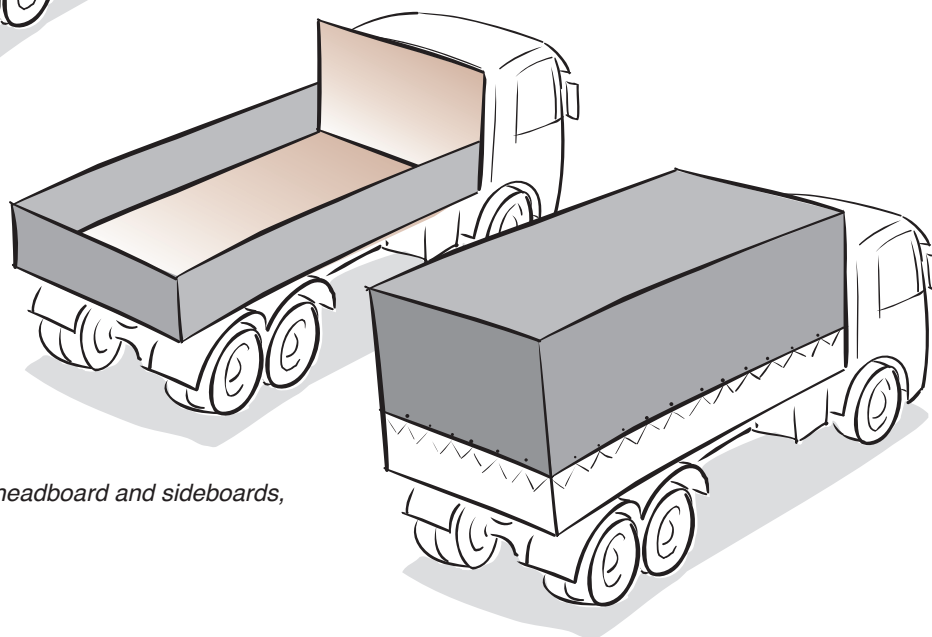

*Flat-bed platform with headboard and sideboards, often with curtainside*

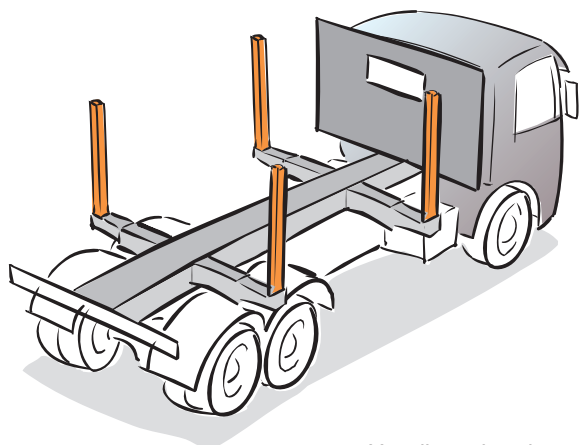

*Headboard and stanchions*

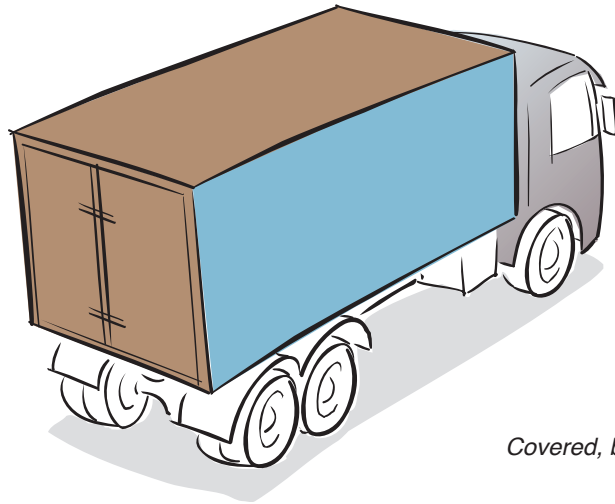

*Covered, built-in flat-bed,  
box-type body*

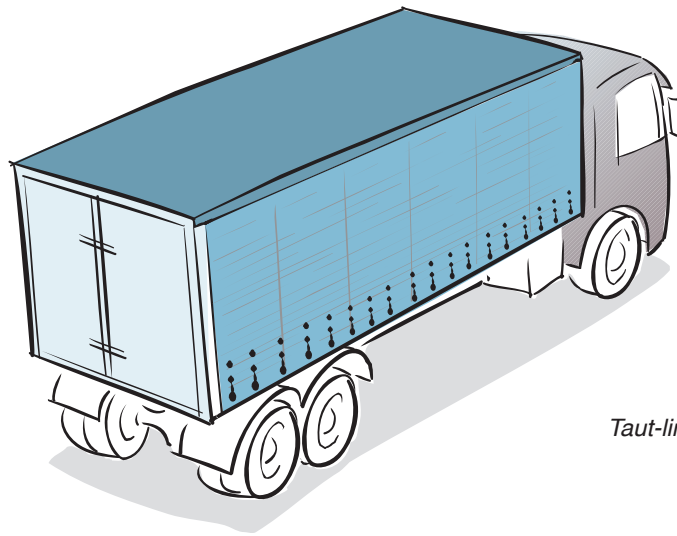

*Taut-liner*

## Trailer

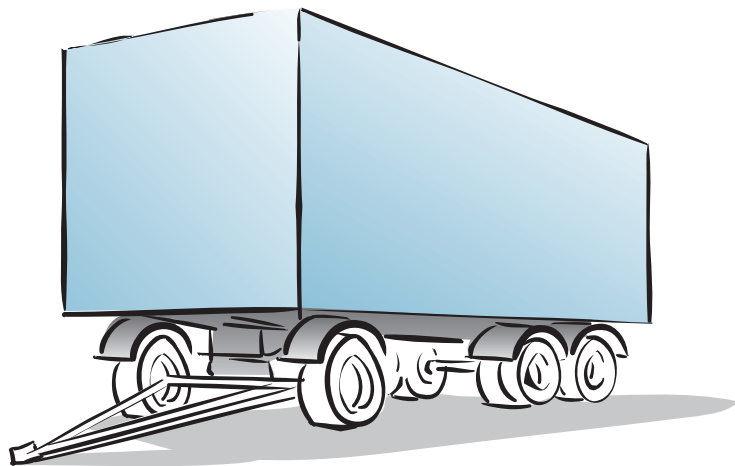

Semitrailer

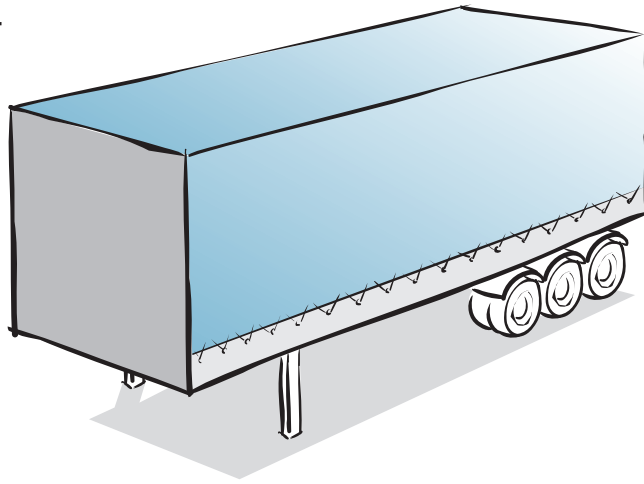

Swap body

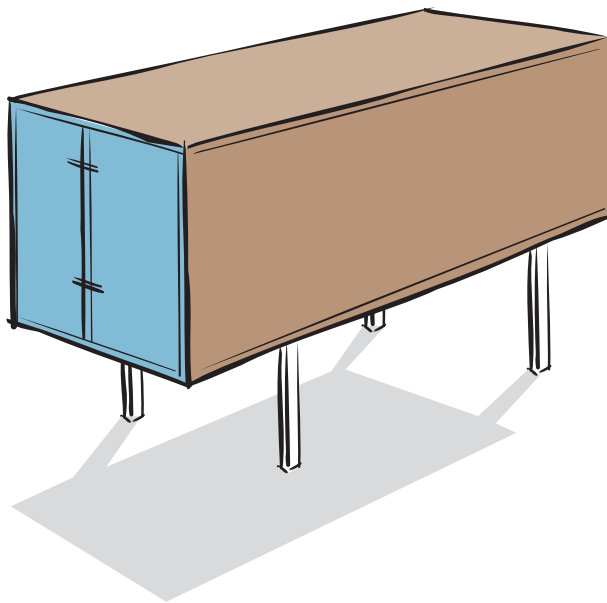

ISO Container

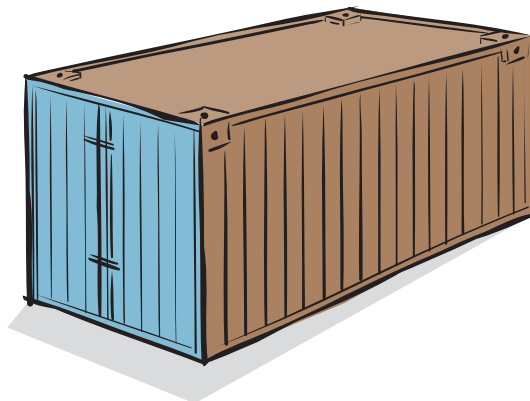

Please note that swap bodies and containers are both load carriers and cargo. They have fixed mounted locking devices to secure them to the vehicles for which they are constructed . The commodities and cargo in the body or in the container must be secured with equipment and methods which will be described later.



International rules regarding the strength of fixed parts of the platform of load carriers or other load securing equipment do not exist. On the whole, it is only the one who has ordered/bought a vehicle who can answer what strain the attachments are constructed for. Therefore, when a vehicle, not known to the driver, is to be loaded, it is a transport worker's merit to critically examine his working equipment and not take for granted that 'somebody else' has specified the limits of safety and security.

## **Vehicles**

There are many standards for the strength of load carriers. They can vary from country to country, vehicle to vehicle, but the general meaning in practice is often the same. We can explain the basis here, **don't forget that you must check your own vehicles strength**. It is recommended to have the vehicle documentation in the vehicles during transport. Naturally the strength of the attachments of the vehicle diminishes gradually as they are used and worn.

## **Platform**

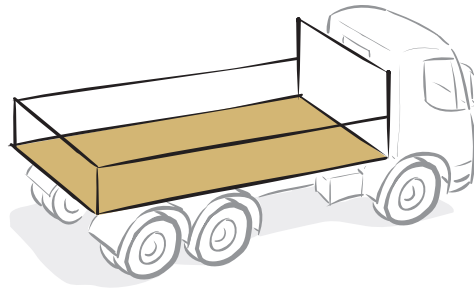

The platform must bear the strain of an evenly distributed load, equal to the maximum payload.

## **Headboard**

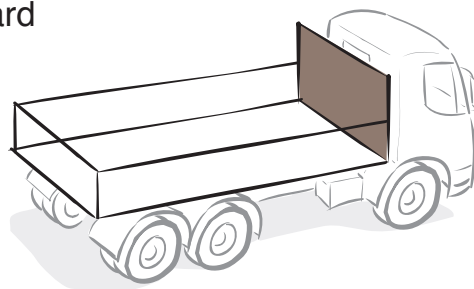

At an abrupt braking (deceleration) the headboard must bear the strain deriving from the payload evenly distributed over the whole area of the headboard. That is the principle the rule of thumb is based on, saying that a blocking must stop the load from sliding forwards, sideways or backwards.

Note, that an incorrect dimension of a blocking or a greater pressure in one point may break the best of headboards.

A load which is not secured can, with the help of a sudden braking, take the headboard with it into the driver's compartment.

## Sideboard and rearboard

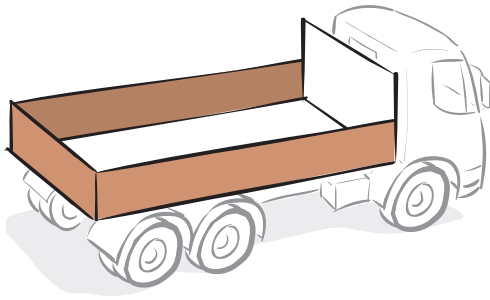

The side and rearboard must bear a strain equal to half of the payload for the vehicle distributed over the whole area of the relevant board.

## Curtain sider

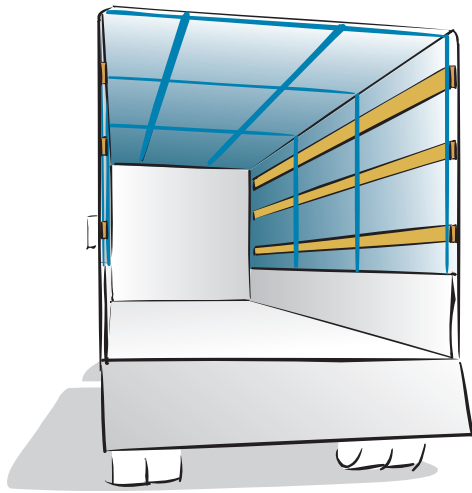

A curtain, rigged over a supporting construction, can as a rule not be approved for securing; it is solely for weather protection. Minor defects in the goods may be difficult to detect. By the strain from the load even a small defect can develop rapidly.

However, curtains like this in top condition with battens and boards may supplement securing the load. In some countries this is allowed as blocking for very light cargo.

## Box type body



The basics for strength of the walls are that they shall clear a strain of 0,3 x the maximum payload (30%) if the strain is spread equally over the whole wall.

## Taut-liner



The curtains on the sides shall in general be seen just as weather protection. Not as supplement to cargo securing. Nevertheless some taut-liners are built with extra strong sides so that they can support cargo securing. An example on this is XL vehicles. If you have a vehicle like this the documentation shows you how much it can support your securing.



Marking for XL vehicle.

## Lashing attachments/points



The lashing attachments on the load carrier must, according to most standards, have a minimum breaking strength of two tons, which is rather low, in view of the fact that a common webbing has a breaking strain of four tons. What strength is chosen for the attachments is however often dependent on what kind of vehicle is used and what cargo it is meant to carry. For example, a trailer for transport of machinery or a vehicle with a crane often have securing attachments with a breaking strain of eight or ten tons, whereas on a box-type vehicle in local distribution transport the attachments normally hold a maximum of two tons.

Remember however, the minimum strength of the attachments we are calculating for in this manual is two tons.

## Webbings



Webbings with tensioners are of many designs, colour, length, width and strength in a mixture that is difficult to survey. They all, however, have in common that they stop being a webbing as soon as any damage becomes visible. Simple dirt, sunlight and rain even for a short time are treacherous and may significantly reduce the strength without any visible indication on the webbing. To take well care of and tend the webbings is rewarding. A more flexible load securing device is hard to find.



The strength of the webbing is shown on a marking tag. Caused to safety reasons you are not allowed to calculate with the whole breaking load using a webbing. Therefore the marking tags shall have figures for LC and  $S_{TF}$ .

- LC (Lashing Capacity) which tells you how much you can calculate with instead of the breaking load. The LC value is calculated from the breaking load with a safety factor.

-  $S_{TF}$  (Standard Tension Force) which shows you the most tension force you can calculate with. This value is taken from standardized tests made by the manufacturer.

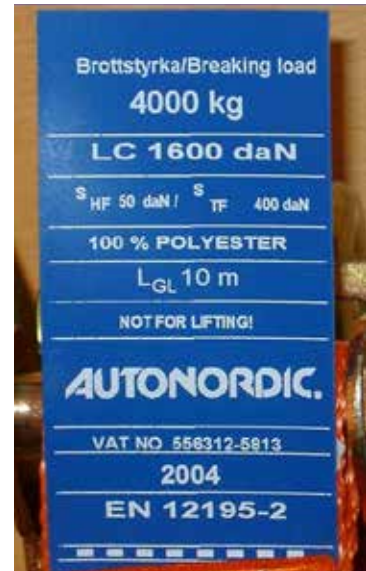

The examples in this book under “Calculating number of lashings” are based on values LC 1600 and  $S_{TF}$  400.

## Chains



The chain is not just a tool. It is also a worn, but a telling symbol for the core of professional cargo securing work: No chain is stronger than its weakest link.



Coupling links

A modern chain has a marking tag showing its strength – often a tag that can serve as a chain-gauge. With the gauge the wear of the links can be measured and you can easily and rapidly decide if the chain is safe to use.

Some chains are marked with WLL instead of LC. WLL stands for Working Load Limit and is used the same way as LC.

## Edge protectors and supporting edge beams/profiles

Sharp corners and edges may, even if they are not as sharp as a knife, quickly cut off for example a strap or webbing. Because the load vibrates during transport, this can happen however well secured it is. Often the cargo has to be protected from the pressure from the lashings. There are many edge protectors to use.



Supporting edge beams have the same protective function. Since they are long and stable in form they effectively distribute the pressure from various lashings. When the load consists of many and light packages demanding only a few lashings, the edge beam comes in handy.

Edge beams are produced in various forms.

They may also be put together by boards, minimum 1 x 4 inches. The nails must be driven through the board on the top down into the edge of the board standing at the side of the load.

## Blocking bars

Blocking bars can simplify the work of securing the load very much, but generally they do not manage to secure loads forwards, since the forces become rather strong at sudden braking.

Blocking bars are often in use in box-type vehicles to secure the load backwards. The bar is kept in place by the friction that occurs when it is pressed between the sidewalls or between the floor and the ceiling. In the interior of a body there are sometimes rails where the bar can be fastened.



On platforms you can find bars that can be hooked on to the sideboards.



## Nets



The most common nets are dimensioned to prevent the load from jumping off or blown away from the platform or open containers. Nets are seldom securing devices when transporting ordinary cargo.

## Wedges – roll-stoppers/blockers.

These are often used for securing cargo with a risk of rolling.

Wedges are in many shapes and materials, often of wood, rubber or metal. In general one strives to get the wedge to have the form of a triangle with its sides in proportions of 3-4-5 in relation to each other, and placed with the 90-degree angle vertically.

*The height of a wedge should be at least one third of the radius of the goods.*

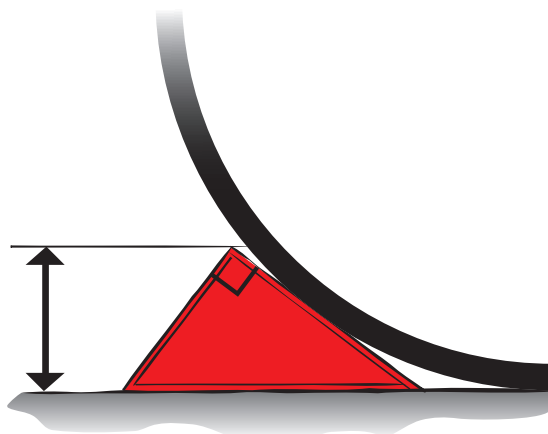

A roll-stopper is often used when paper rolls, cable drums or vehicles are transported. It consists of two wedges joined by a tensioning device.



## Timber shocking nailed battens

These are used to prevent sliding and are, correctly utilized, very effective. A floor blocking by nailed timber should be at least five centimetres in height to be useful. The nails must be driven down at least four centimetres into the wooden platform, and never closer than five centimetres between the nails.

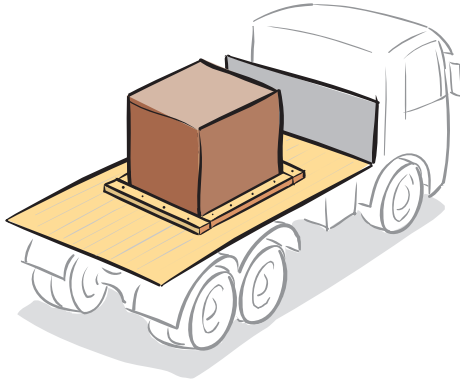

Goods weight in tonnes where <u>one</u> nail will stop <b>sliding movement</b>						
$\mu$	Sideways <i>each side, 4"-nail</i>		Forwards <i>4"-nail</i>		Backwards <i>4"-nail</i>	
	<i>Plain nised</i>	<i>Galv-nised</i>	<i>Plain nised</i>	<i>Galv-nised</i>	<i>Plain nised</i>	<i>Galv-nised</i>
0,2	0,36	0,53	0,18	0,26	0,36	0,53
0,3	0,55	0,80	0,22	0,32	0,55	0,80
0,4	1,1	1,6	0,27	0,40	1,1	1,6
0,5	<i>no risk</i>	<i>no risk</i>	0,36	0,53	<i>no risk</i>	<i>no risk</i>
0,6	<i>no risk</i>	<i>no risk</i>	0,55	0,80	<i>no risk</i>	<i>no risk</i>
0,7	<i>no risk</i>	<i>no risk</i>	1,1	1,6	<i>no risk</i>	<i>no risk</i>

These values are taken from the IMO Model Course 3.18 and recalculated in accordance with EN 12195-1: 2010.

The cargo is also secured against tipping over if the battens reach over the centre of gravity

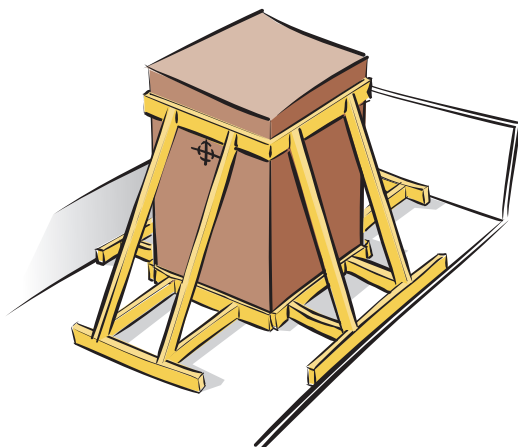



Another method to prevent sliding similar to nailing battens is to use tag washers. These are very useful in transport of pallets on wooden platforms. A tag washer has sharp edges pointing upwards and downwards and is placed between the load and the platform.

Goods weight in tonnes where <u>one</u> tag washer will stop <b>sliding movement</b>							
	Ø 48	Ø 62	Ø 75	Ø 95	30 x 57	48 x 65	130 x 130
$\mu$	<b>Sideways/backwards</b>						
0,2	0,41	0,58	0,75	1,0	0,41	0,58	1,3
0,3	0,62	0,87	1,1	1,5	0,62	0,87	1,9
0,4	1,3	1,8	2,3	3,0	1,3	1,8	3,8
$\mu$	<b>Forwards</b>						
0,2	0,20	0,29	0,37	0,50	0,20	0,29	0,62
0,3	0,25	0,35	0,45	0,60	0,25	0,35	0,75
0,4	0,31	0,43	0,56	0,70	0,30	0,43	0,93

These values are taken from the IMO Model Course 3.18 and recalculated in accordance with EN 12195-1: 2010.

If the material in the platform does not allow nails it is possible to place the battens as H-constructions where the battens are nailed together. These H-constructions can be made on the platform to prevent sliding or standing between different goods or between goods and parts of the vehicle. Standing they often prevent both sliding and tipping over.

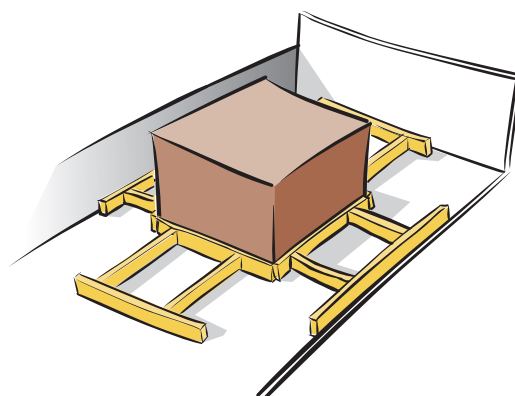
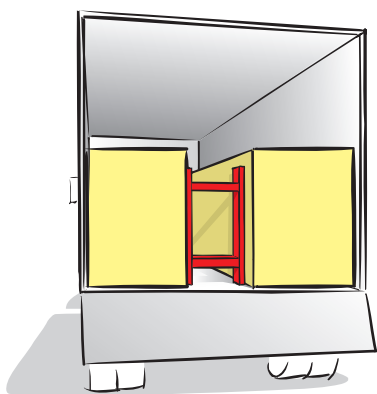

Always when using nailed battens remember that the battens must be dimensioned to hold the weight of the cargo in relation to the stipulated forces.

## Filling material



When the load is blocked there might be some space between the packages, which has to be filled. Nowadays air bags are often used. They are good, but may damage the cargo or press the sideboards and body sides out if you blow them up too much. The pressure must not be more than is recommended by the manufacturer. Another very common method to fill empty space is to use wooden pallets.

## Material to increase the friction

Friction must be cared for and increased as much as possible, since roughness between cargo and bedding reduces the risk of sliding. There are several ways to help.

Discarded tires ground and vulcanized together into friction carpets are used to place under the load. The same function has paper with a rubber film.



Friction mats are in some countries often used under the cargo. The manufacturers show in certificates what coefficient of friction you are able to use with their material.



## ***To load vehicles is to build vehicles***

When a lorry or trailer is constructed great efforts are put in to make the vehicle stable to drive. Advanced calculations are done using complicated computer programmes. The results are analysed and many prototypes are built and tested before serial production can start. It can take years and cost many millions to produce a new transport vehicle.

But the constructors do not have a crystal ball to show all those loads of cargo the vehicle will transport during its lifetime. Nobody knows exactly how all of them will look, the weight of them and – most important – how they will be placed and secured on the vehicle. One can say that thousands of man-hours of construction work are thrown into the sea in a blink if the vehicle is loaded in an incorrect way.

He who loads in such a way that the vehicle is burdened incorrectly has in a short time “built” a completely new and maybe life threatening vehicle, dangerous to other traffic and the environment, too heavy for roads and bridges.

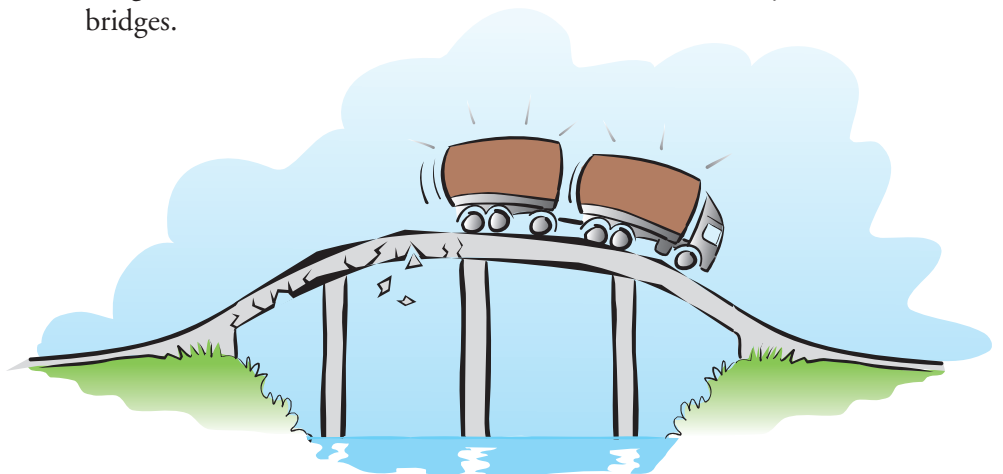



The driver must always plan the transport. He must take care the cargo is distributed equally over the platform. The limits of maximum load, the forward axle pressure and the bogie pressure must not be exceeded. Sometimes the driver must also consider if some part of the load will be discharged and/or new packages will be added before the final destination.

However, plans are usually desk-products. For example during transport road accidents, new orders or other events may require a new route to be taken. This may cause loading and discharging in a sequence other than was planned. It is always the responsibility of the driver to ensure the balance is kept and no maximum load limits are broken.

### ***Many ways of overloading***

All changes of the total weight of the vehicle and the distribution of the weight affect the driving ability and risk of accidents. A lorry unfortunately has not the sense of balance of man. He who loads a breakfast tray maybe puts what can slide around against an edge; if it is the teapot that slides, the muscles in the arm can counteract the change in balance, even over thresholds and on stairs.

A vehicle cannot do this. Too much cargo on one side of the platform makes a vehicle difficult to steer and in the end it may roll over. With too much of the load against the headboard a vehicle gets oversteer and an overload at the rear makes it understeer. Even if the total weight of the load is less than the total load limit, the pressure on the front or rear axle, or on the road, may be higher than allowed.

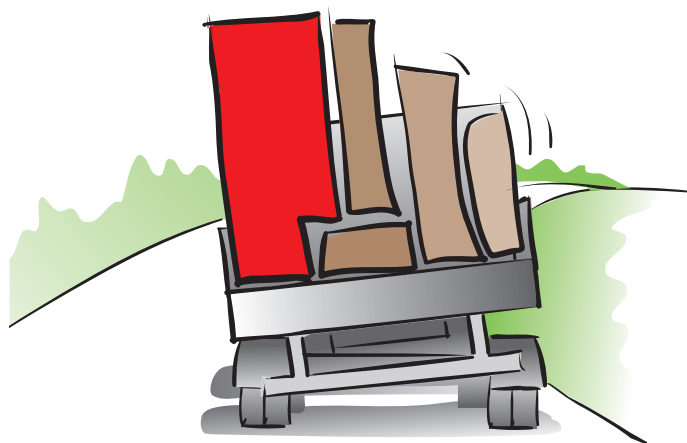

*With an overload at the sides the steering gets difficult; especially in curves the risk of tipping increases.*

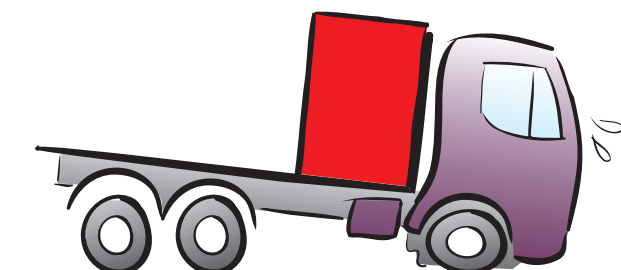

*With an overload at the front the front-axle pressure gets too high and the vehicle oversteers.*



*With an overload at the rear the rear-axle pressure gets too high and the vehicle understeers*

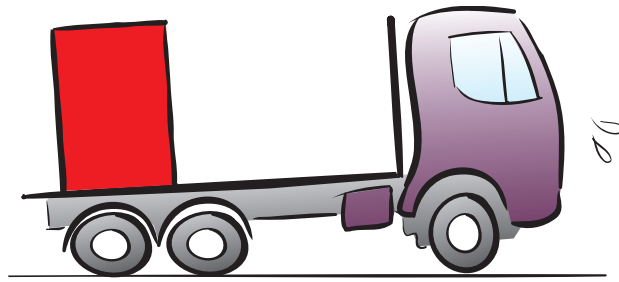

Consequently you can overload the whole vehicle and/or overload parts of the vehicle.

Manuals on safety in traffic that are packed with warnings risk counteracting their purpose.

Regarding overload of vehicles even experienced drivers may agree that some nagging about it may be justified. It is often the slightest effects of overload that hit, especially the driver, the most. The fact is, it does not matter who had the responsibility for the loading when an overloaded vehicle is inspected by the police. Even if responsibility and fines are laid upon the sender or carrier, it is the driver standing there in person getting fined himself. It is the driver who has to arrange reloading, it is the driver who gets the blame when an incomplete delivery arrives late, and so on. An overload may, in addition, cause damage to cargo and – last but not least – traffic accidents with tragic outcome.

### ***International laws and regulations***

In different countries different laws are current. Planners of transport and drivers must have a knowledge of these, but do not have to look up the actual text of the law. There are summaries of the most important rules for several countries. This concerns also the maximum total weight of a vehicle and vehicle combinations. These can vary between countries.

### ***Vehicle documents***

The vehicle documents include specifications needed to load correctly and legally. They say how much a vehicle can be loaded – maximum load and highest axle-pressures allowed.

In some countries there must be a specification in the vehicle document stating where the centre of gravity of the load in relation to the rear-axle is to be situated.

### ***Consignment note, Bill of lading, Waybill***

The consignment note must show:

- the weight of the cargo
- how spacious it is (volume)
- how it is packed
- handling instructions (fragile or dangerous cargo)



The sender of dangerous cargo must complete field 5 on the CMR-waybill with the classification according to ADR.

In field 6 the sender or receiver can give instructions about loading and securing.

### **National waybill**

Regarding national transport many countries have their own, standardized consignment notes. Sometimes they may be valid for transport to a neighbouring country.

All partners include their own.

### **Load and distribute**

With details of the loading capacity of the vehicle and data about the weight of the cargo and other conditions the loading can start. There are so many types of vehicles and cargoes that detailed rules cannot be given. Use must be made of the data for the transport that are available together with theoretical knowledge, professional experience, fantasy and common sense.

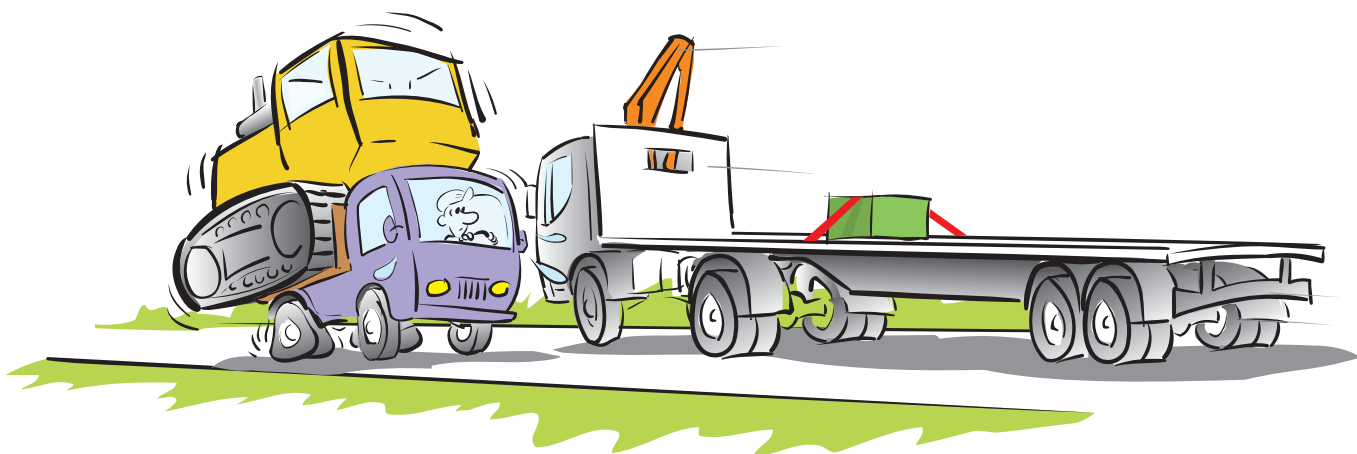

- The goods are distributed equally over the platform.
- The limits of maximum load and axle pressure must not be exceeded.
- The goods must be loaded in such a way it is possible to secure it.

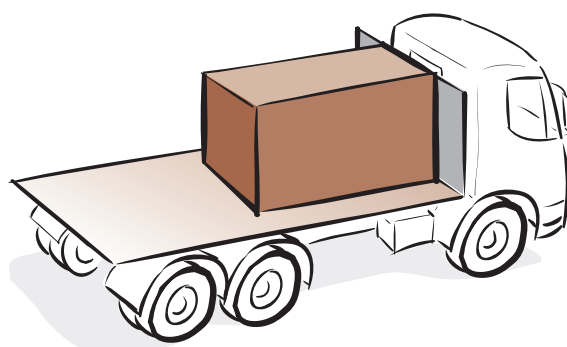

*The simplest and often the safest location is against the headboard.*

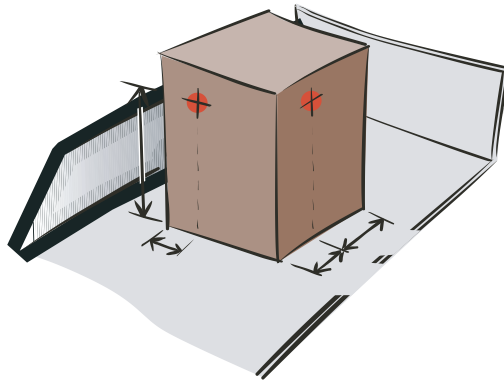

*If cargo against the headboard overloads the front axle it should be placed at a suitable distance from the headboard. The space inbetween is filled with other cargo, empty pallets, battens or in other ways described in the next section.*

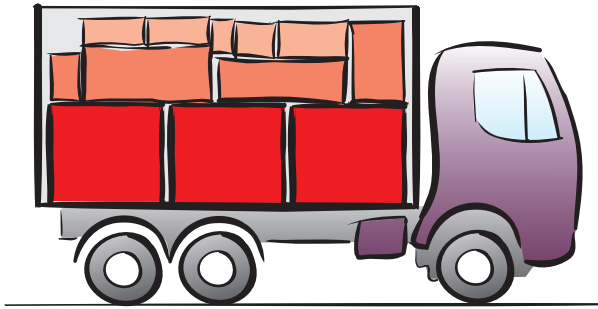

*Heavy goods must be placed lower than lighter goods. This lessens the risk of damage to the goods by pressure and gives the whole carriage a lower and thus safer centre of gravity. The centre of gravity of a single package must also be situated as low as possible to prevent it from tipping over.*

### **Order of loading and distribution**

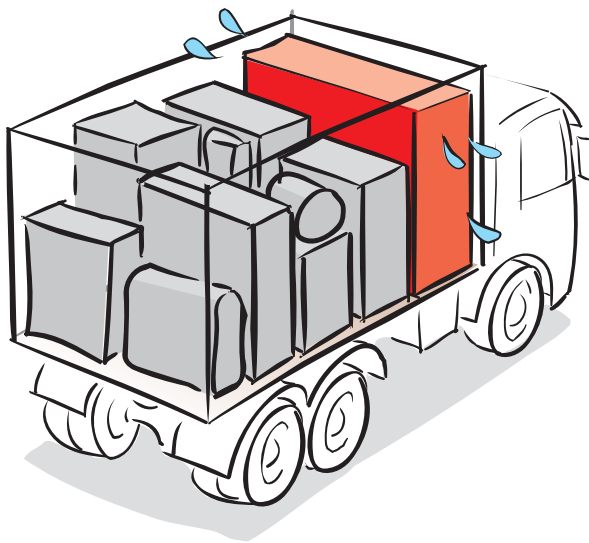

First in – last out. That is the simplest rule of loading for efficient transport work. Unfortunately this rule is often in conflict with the demand for distribution of weight and securing of cargo. If the transport has several destinations it happens that senders place the goods on the loading bay in the order it is to be distributed. This contributes to efficiency. But the safety of the transport is the responsibility of the driver. Count on being forced to load in an inconvenient but safe order and to re-allocate the cargo when parts of it are discharged.

# METHODS AND PRINCIPLES

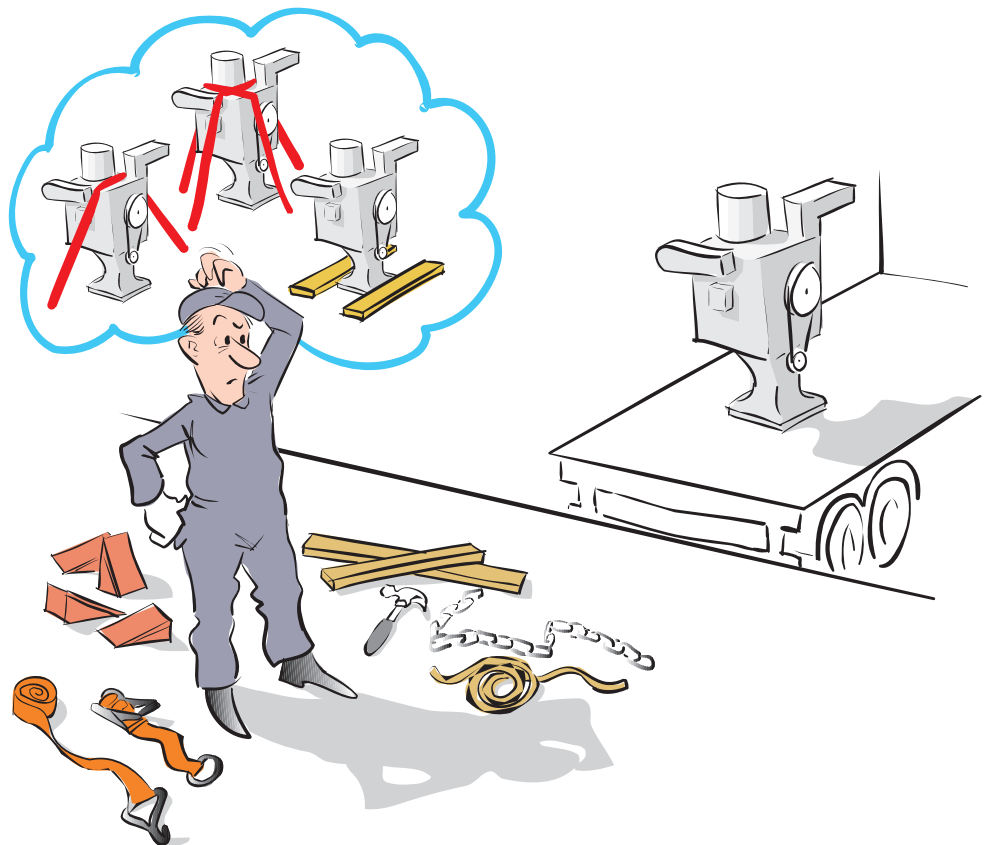

A thorough work of loading is wasted effort if the cargo is not secured. The forces the cargo is exposed to during transport are of a kind that start to grow extraordinarily rapidly and often in strength when the cargo starts moving.

Cargo securing seems obvious if one imagines fragile computer equipment or maybe an antique floor-clock standing on a platform, which is thoroughly blocked and lashed. Less obvious is perhaps that even a load of blasted rock must be secured. The ignorant viewer does not see what has been done in positioning the goods in specific relation to the parts of the platform.

Securing cargo is, in other words, the art of combining the characteristics of the goods, parts of the vehicle, the securing- and the lashing equipment, in such a way that the cargo and the vehicle become one unit.

The goods must be secured so that they cannot slide, tip over, move around or fall off the vehicle. The lashing must bear a strain forward of the full weight of the cargo, half its weight to the sides and backwards. In this section we will show how to prevent sliding by blocking the cargo against for example the headboard and other cargo, or by lashing. Similar methods and lashings, often by webbing, are used to prevent tipping. The tendency of goods to move due to vibrations is relatively simple to prevent.

## Blocking

### Blocking against parts of the vehicle

Blocking against parts of the vehicle signifies that the load is placed in close contact with the headboard or the sideboards. If the transport contains several cargo units they must be packed as close together as possible. Space between can occur, for example, due to the shape of the goods and should be filled out with pallets, airbags or other material. In a section/row a total open space corresponding to the height of a European pallet, (144 mm) is acceptable. That is to say; if the load can be stowed together to make space for a pallet, it should be done that way and a pallet be put there. All unnecessary, empty space must be avoided.

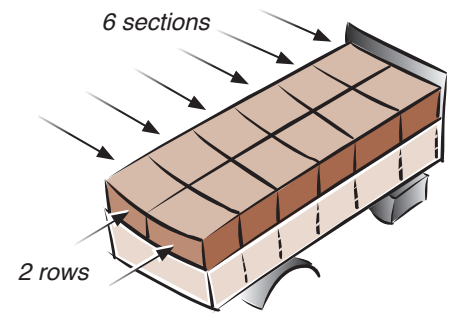

### Blocking by timber chocking

Blocking by battens against fixed structures of the load carrier.

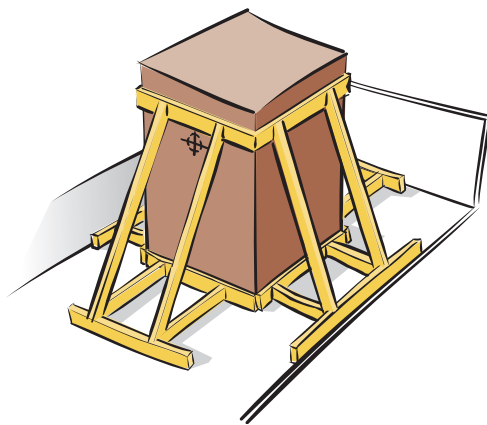

The load must at times, due to its form or weight, be placed in a position on the platform than against the headboard or a sideboard. Then a construction of timber chocking and nailed battens prevents the load from sliding. The dimensions and number of the battens is estimated to bear – do You remember? – yes the the whole weight forward, half the weight backwards and to the sides.

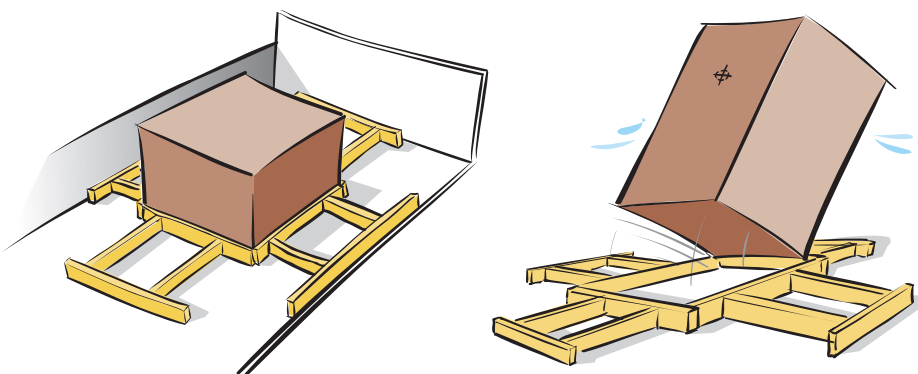

Laying battens are nailed to the floor as with, for example, brace-blocking to the sides of the platform. Remember to lash the load, if any risk of tipping remains – see the table for the number of top over lashings to prevent tipping.



## Lashing

Lashing is most often done by webbing or chains.

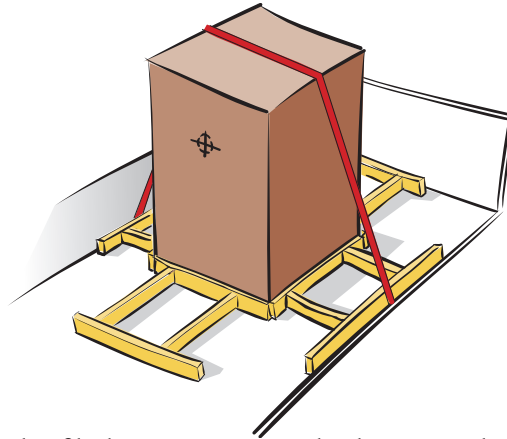

Many methods of lashing assume an edge beam or edge protection is used to protect the equipment. The lashing must of course not damage the load either.

The tables for finding the number of lashings in this manual are calculated for:

- webbing or straps with LC 1600.

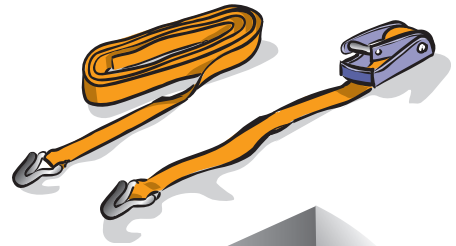

- fitted lashing points with minimum strength of 2 tons.



- well-stretched webbings with  $S_{TF}$  400 kg during the whole transport.



To find the number of lashings needed, you must: start by finding the number of lashings needed to prevent sliding, then find the number of lashings to prevent tipping. The highest of these numbers is the valid number. If the result shows no lashing is needed to prevent sliding or tipping, the risk that the load can move around remains. Therefore the number of lashings to prevent 'walking' must be calculated.

For these calculations the tables in the 'Simple Guide on Securing Cargo', annexed to this manual, may be used.

Under 'Top-over lashings' below, an example is shown of how to calculate the number of these lashings.

### Top-over lashings.

The 'top-over lashings' run from side to side over the load. This is excellent as a securing method, but has an important limitation. The lashing is most efficient if the angle between the loading platform and the upright part of the lashing is 90 degrees. If this angle diminishes the lashing loses in effect. The table to find the number of lashings is calculated for an angle between 90 and 75 degrees. At angles between 75 and 30 degrees the number of lashings must be doubled.

If the angle is less than 30 degrees the lashing has almost no effect and another securing method must be used.

The positioning of the straps or webbing is critical too, primarily for the possibility to prevent tipping forwards/backwards. When a lashing is used it must be placed over the centre of the load.

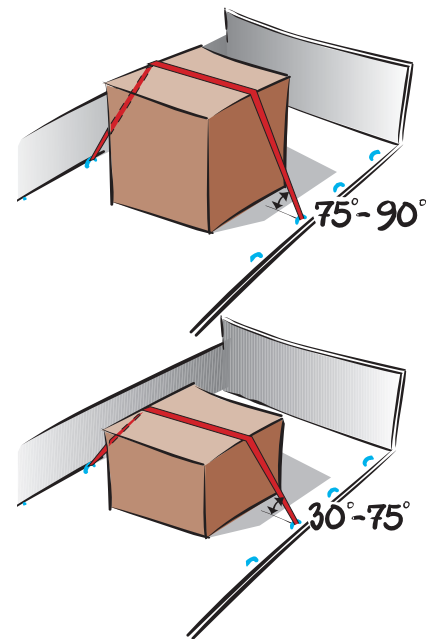

If there are several top-over lashings they must be evenly distributed over the load.

## Loop lashing

Using a loop lashing will secure the load on each side with a pair of webbings. At the same time you prevent the load from tipping. Use at least two loop lashings per unit of goods.

If there is more than one section on the load and the sections support each other and stop any twisting from occurring, then you may need only one loop lashing per section of the load.

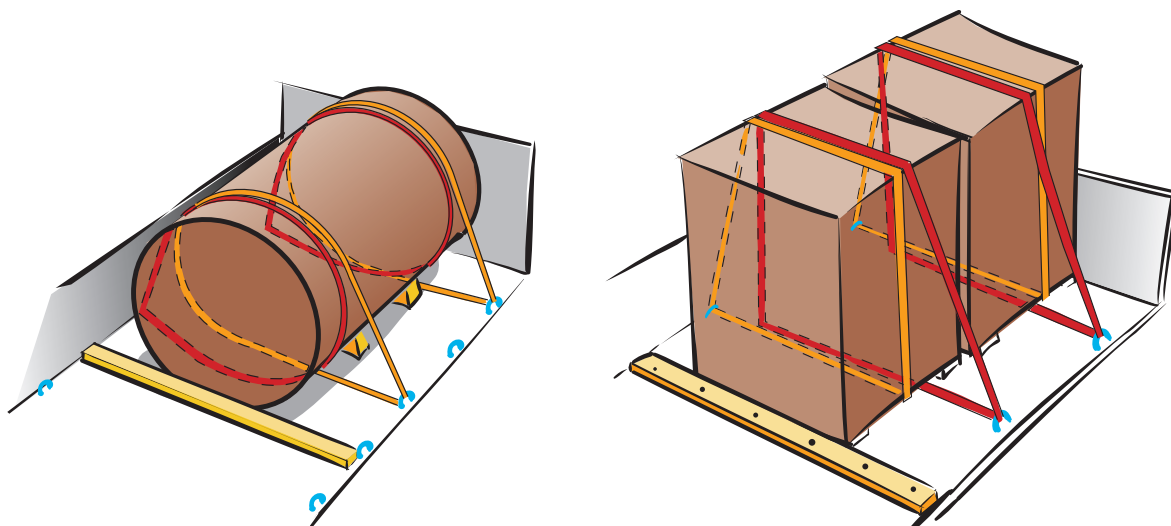

## Spring lashing

A spring lashing is used to block the load in the forward or backward direction and can solve many loading problems, in particular when a lorry or a trailer platform is loaded full and you need to load a second layer. Often the load in the upper level must be placed away from the headboard in order not to exceed the limits of axle pressure. A spring lashing is then a good solution.



A spring lashing can be made in various manners, but they have in common that the angle between the platform and webbing or straps must not exceed 45 degrees. A spring lashing rapidly loses its effect when the angle is greater. The tables in the manual are worked out for an angle up to 45 degrees.

To prevent tipping it is important that the spring lashing reaches as high as possible up the load. The amount of weight (tons) a spring lashing can prevent tipping according to the table diminishes in direct proportion to the height of the lashing. In practical terms: a spring lashing at  $3/4$  high up the load has  $3/4$  effective prevention, half up it is half effective, and so on.

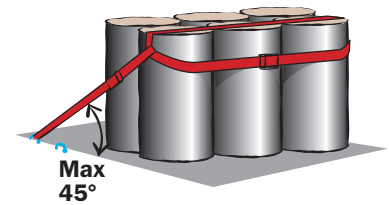

When the load is in sections, to find the risk of tipping in the forward or backward direction it is sufficient to calculate it for the weight of the last (farthest out) section only. However, don't mix this rule with the rule for sliding. In that case the full weight of the load has to be considered.

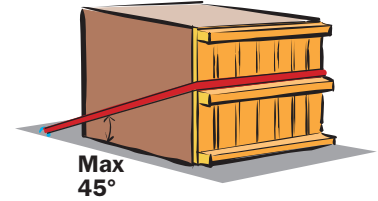

A spring lashing with two straps (legs) per side secures twice as much as a single strap on each side. If you have a spring lashing with two straps the values in the tables in the handout can be doubled.

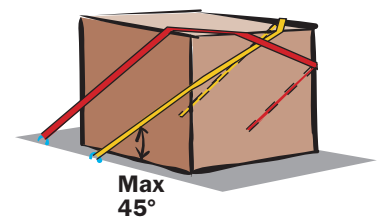

### Straight lashing – Cross lashing

This type of lashing is used primarily on larger machinery and cargo where you can attach the lashing directly to the cargo. This lashing prevents both sliding and tipping. Depending on the angle between the attachment point on the cargo and the attachment point on the floor, the effect to prevent tipping is different to that of sliding.

If the lashings are put crossways (cross lashing) it is of utmost importance that the cross occurs over the centre of gravity of the cargo - otherwise the lashing helps the cargo to tip over.



*Straight lashing*



*Cross lashing.*

How many tons a straight or a cross lashing can prevent from sliding and tipping is dependent on so many factors a 'Simple Guide' with weight tables cannot be made.

## Round-turn lashing

The Round-turn lashing is often used to prevent tipping, and it makes the load do the job. Many packages, inclined to tipping, e.g. standing barrels on a platform, can be lashed with a horizontal strap around them to prevent each other from tipping. Several units become one. Remember the longer the strap or webbing is, the more it stretches; a round-turn lashing becomes useless if it is too long.

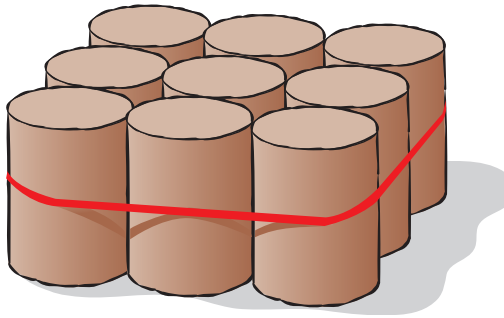

*Horizontal*

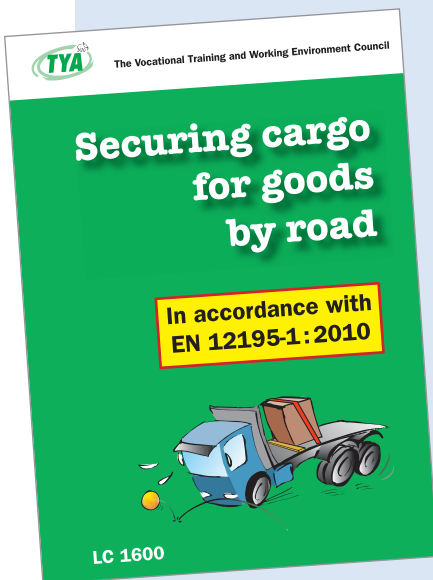

## CALCULATING NUMBER OF LASHINGS

To know exactly how much a lashing can bear and secure often requires a number of rather complex calculations. To make that work more simple for you, we have done these calculations and present them in tables with this manual as 'Simple Guide tables' with precalculated values. To decide the dimensions of the lashings you will, in most cases, be able to use this guide with pre-calculated values. You may, however, encounter special situations difficult to calculate. The commodity, the load carrier or the blocking equipment at your disposal may not correspond to the preconditions of the table. For such events more advanced calculation methods are needed, which are often done by specialists in cargo securing in your firm or by consultants.

To calculate the number of lashings needed to prevent sliding and tipping, first look up how many lashings you need to prevent sliding. Secondly you look up how many lashings you need to prevent a tipping. The highest number of these shows how many lashings you, at least, have to use.

An example of a calculation of the number of top-over lashings needed to secure a wooden case with dimensions: Breadth 2 metres, Length 2 metres and Height 2,4 metres. The wooden box weighs 2,4 tons and is placed on a wooden platform as shown in the picture. It is not blocked in any direction. In this example the cargo is homogeneous, meaning it has its centre of gravity at its midpoint. The number of top-over lashings is decided by use of the measurements and the figures in the table.

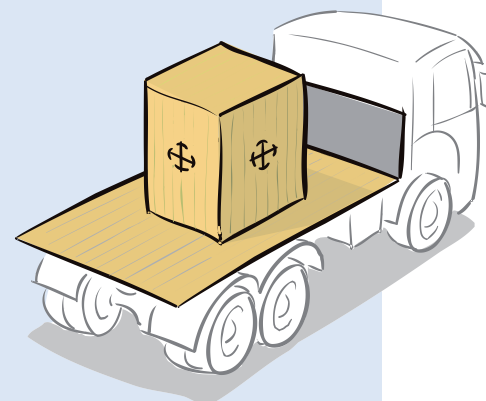

First the number of lashings to prevent **sliding** must be calculated:

**Step 1.** According to the table of friction the friction factor ( $\mu$ ) for a wooden box on a wooden platform is 0,45.

## Sliding

The friction between the goods and the loading platform (or cargo beneath it) has a huge influence on how much goods one lashing can hold. If you find the combination of materials in the table below you may use its values under condition that both the cargo and the surface underneath are swept clean and without frost, ice or snow. Otherwise you shall use the friction factor ( $\mu$ ) = 0,2.

Special precautions shall be taken if the surfaces are oiled or greasy.

The values in this table are for both dry and wet surfaces.

Combination of materials in the contact surface	Friction factor, $\mu$
<b>Sawn wood</b>	
Sawn wood – fabric base laminate/plywood .....	0,45
Sawn wood – grooved aluminium .....	0,40
Sawn wood – shrink film .....	0,30
Sawn wood – stainless steel sheet .....	0,30

## Combination of materials in the contact surface

## Friction factor, $\mu$

### Plaine wood

Plaine wood – fabric base laminate/plywood .....	0,30
Plaine wood – grooved aluminium .....	0,25
Plaine wood – stainless steel sheet .....	0,20

### Plastic pallet

Plastic pallet – fabric base laminate/plywood .....	0,20
Plastic pallet – grooved aluminium .....	0,15
Plastic pallet – stainless steel sheet .....	0,15

### Steel and metal

Steel crate – fabric base laminate/plywood .....	0,45
Steel crate – grooved aluminium .....	0,30
Steel crate – stainless steel sheet .....	0,20

### Concrete

Concrete rough – sawn wood battens .....	0,70
Concrete smooth – sawn wood battens .....	0,55

### Anti-slip material

Rubber .....	0,60
Other material .....	According to certificate

**Step 2.** In the Table of Sliding we can see that when the friction is 0,45 one top-over lashing prevents from sliding. On the other hand the load can slide forwards at braking (deceleration) and we can see that one single lashing prevents 0,8 tons (800 kilos) to slide forwards. **Consequently three lashings are needed** ( $3 \times 0,8 = 2,4$  tons) to prevent the box from sliding forwards.

## Top-over lashing

Using the table below, you must note that the angle between the lashing and the loading platform is of great importance. The tables should be used for angles between  $75^\circ$  and  $90^\circ$ . If the angle is between  $30^\circ$  and  $75^\circ$  double amount of lashing straps are needed, or you halve the table values.

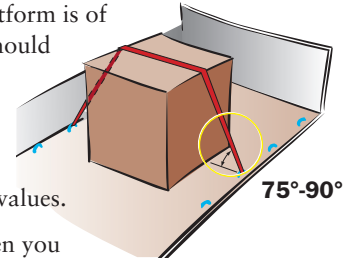

If the angle is less than  $30^\circ$ , then you must use another method of securing the load.

**Goods weight in tonnes where one top-over lashing strap will stop sliding movements**

$\mu$	Sideways	Forwards	Backwards
0,15	0,31	0,15	0,31
0,20	0,48	0,21	0,48
0,25	0,72	0,29	0,72
0,30	1,1	0,38	1,1
0,35	1,7	0,49	1,7
0,40	2,9	0,63	2,9
0,45	6,4	0,81	6,4
0,50	<i>no risk</i>	1,1	<i>no risk</i>
0,55	<i>no risk</i>	1,4	<i>no risk</i>
0,60	<i>no risk</i>	1,9	<i>no risk</i>
0,65	<i>no risk</i>	2,7	<i>no risk</i>
0,70	<i>no risk</i>	4,4	<i>no risk</i>

© TYA, 2014

12

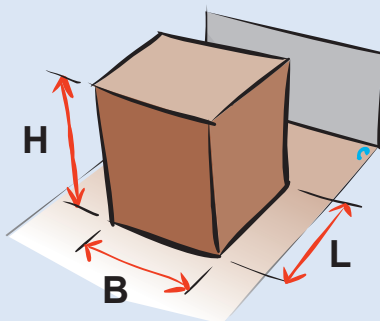

Now the number of lashings to prevent **tipping** has to be calculated:

**Step 3.** First we must see the relations for  $H/B$  and  $H/L$  :  $H/B$  is height 2,4 metres and breadth 2 metres giving  $H/B = 2,4/2$  which makes  $H/B = 1,2$ .  $H/L$  is done in the same way, height 2,4 metres and length 2 metres make  $H/L = 2,4/2$  making  $H/L = 1,2$ .

**Step 4.** In the table of tipping we then see that for an  $H/B = 1,2$  there is no risk of tipping sideways for one row of cargo, for an  $H/L = 1,2$  there is equally no risk of tipping backwards, while on the other hand there is a risk of tipping forwards and that each lashing secures 4 tons of cargo. **Consequently, one single lashing** is needed to prevent tipping.



**Step 5.** Because the greatest number of lashings is needed to prevent the sliding, that number is the minimum. Accordingly, to secure the case in the example, three top-over lashings are needed.

As there now is a lashing this also takes care of the risk of walking

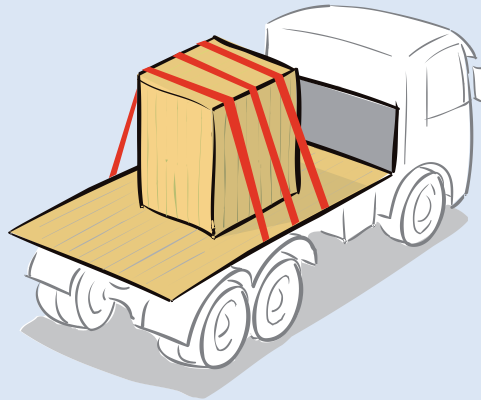

#### Displaced centre of gravity.

To calculate the number of top-over lashings for loads or cargo with a displaced centre of gravity the same method of calculation as before will be used. However note the measurements for calculating H/W or H/L will be different.

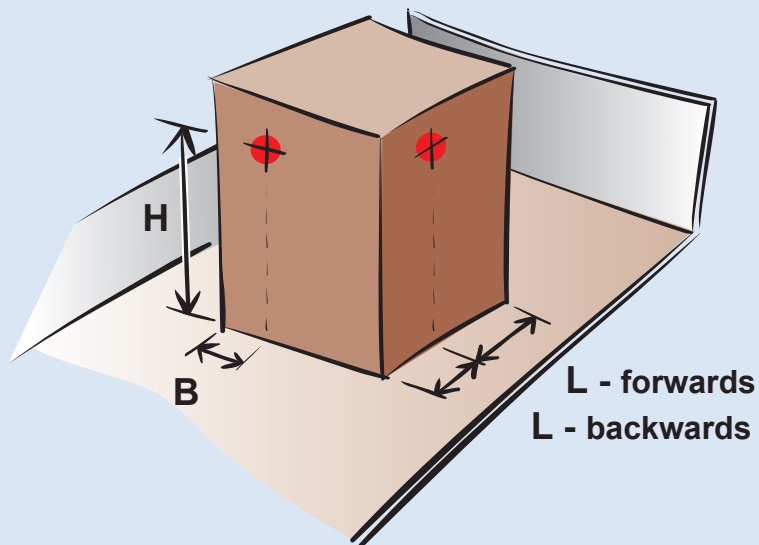

He, who can make risk-calculations for top-over lashings has a good base for doing similar calculations, in a simple way, for other cargo and cargo securing methods. In practice, you may often have lighter cargo blocked against e.g. the headboard and do not have to calculate the risk of tipping and sliding in all directions. But if at work you have a simple guide with calculated tables at hand and master the calculating method well, significant parts of the risk of accidents in transport can be avoided.

Cargo can be anything and this fact might be rather frightening to those who want to do transport work of high quality. But the securing methods are, to the joy of everyone, not as many as types of cargo and commodities. This is because cargo can be classified into categories and in each category we can often use the same standards for securing. Transport workers have over the years developed many tricks and improvements that make the securing more easy.

## ***General cargo***



General cargo is the major cargo category. It is transported mainly by curtain-siders, taut-liners and box-type vehicles. The shape of the cargo, weight and friction can vary endlessly. To secure a load, consisting of several kinds of general cargo for transport, which has to be loaded and discharged several times and at several destinations, can be like a puzzle. There is only one basic rule: the heavy cargo at the bottom, block, block and block, then lash if needed.



In situations when the load and the forces of nature do not conform to our rules for securing cargo, we can counteract them with professional knowledge, experience from work and imagination, that is: Load in a correct order if the cargo is to be discharged at different destinations. However, at the same time pay attention to put heavy cargo at the bottom and preferably block it against the headboard. If the most heavy cargo is placed further to the rear, a construction of bars may solve the problem. The bars may additionally create space and floor blocking to other cargo as well. The load securing may be completed with air bags, pallets and lashings.

A great part in transport of general cargo is unitized. A trailer filled with one single type of cargo naturally simplifies the securing substantially. From industrial producers daily similar transports of cargo are usual, thus creating a pattern for calculating the securing method to be used repeatedly.

The paper industry has many examples of unit loads. They may consist of paper sheets on pallets filling the platform from headboard to the rearboard. To take as much cargo as possible, a couple of pallets are placed on top of the first layer. The upper pallets are put close to the rear axle to spread the pressure correctly. Securing the upper pallets in the travelling direction can be done by blocking, using boards, battens or creating a threshold.

*Blocking by wooden battens:*

Between the pallets in the bottom layer boards or battens are placed sticking up in front of the pallets in the upper layer.



*Blocking by a threshold:*

Empty pallets are placed underneath a section of pallets in the bottom layer to create a threshold on top, which can block the pallets in the top layer.



All blocking of palletized general cargo is made more easy due to the fact that the measurements of the platform are based on the length and breadth of an I.S.O. standard pallet. That's to say the breadth of the platform is equal to the sum of two of the longer sides of the pallets or the sum of three of the shorter sides of the pallet.

### **Crates and roll-containers**



For smaller general cargo crates are often used especially in distribution where every receiver has its own. Blocking is the most common method to secure crates. It is done against each other or against the vehicle equipment. To the rear it is usually secured by a beam or a webbing or straps with a tensioner.

### **Bulk cargo**

All transport of bulk cargo needs a bulk vehicle or a vehicle with headboard, sideboards and a rearboard.

This is obvious since bulk cargo is cargo without any wrapping, e.g. earth, sand, pebbles or boulders. It may also be farm produce like cauliflower and beets.

Beside a tarpaulin or net to cover the load if it can emit dust or fall off, there is the following general rule for transporting bulk cargo.

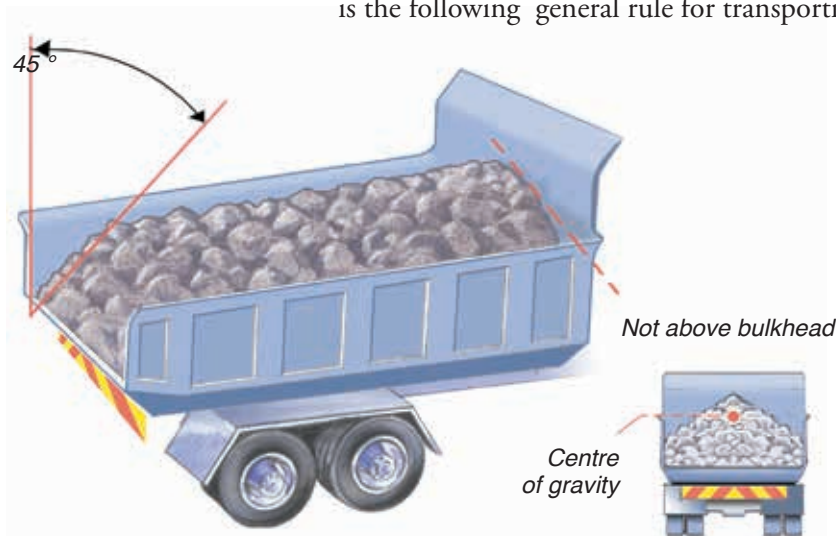

- When the load has been levelled, the centre of gravity of any unit (e.g. a stone) in the load must not be above the headboard or sideboard or similar device.
- To the rear no load unit should have its centre of gravity above a line of 45 degrees above the rearboard.



## ***Long goods***

Nowadays rather boring trick in films to entice people to laugh is to let a plank be carried on someone's shoulder to swing around and knock a poor creature unconscious. In a similar way in traffic the driver of a short lorry with an extra long load, becomes a movie star only in the police crime register.

With their special vehicles manufacturers have released us from such dubious comics. The so-called ironmonger's lorry is a common example. It certainly looks funny with its cut off driver's compartment, but it solves the problems of transporting long cargo.



Some very long cargo is suitable for transport by a trailer engine and a bogie. The load becomes an integral part of the vehicle.



Common for most transport of long cargo is that if the load sticks out in front or behind the vehicle it must be equipped with signal flags or the like.

## **Liquids and gases under pressure**

Gases are transported by tank lorries or in cans. A tank is already fixed to the frame of the vehicle, but loose cans must be secured by the driver or the loader.

Cans are usually transported standing upright, lashed to the headboard or the sideboard. The cans may also be put into a crate which must be secured in the same way as other types of cargo.

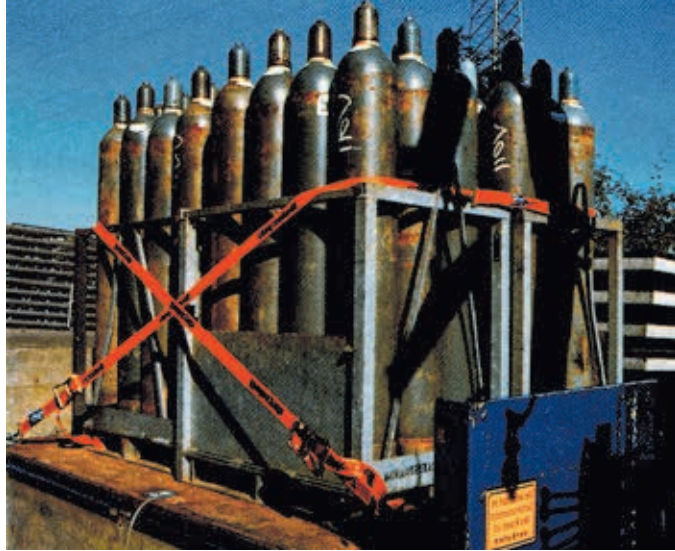

## **Barrels**

The methods to secure barrels vary, e.g. to how big a load it is.

A few barrels may often be blocked and lashed with an extra spring- or round-turn lashing.

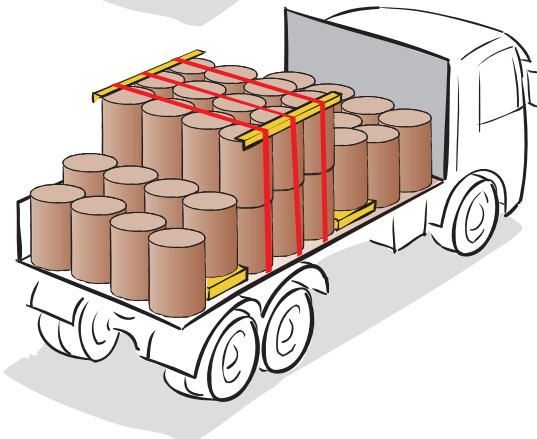
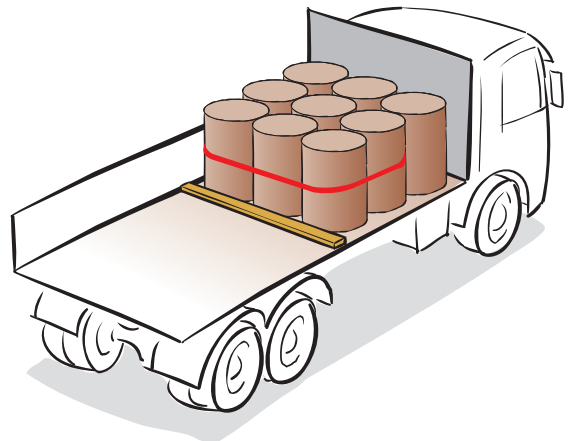
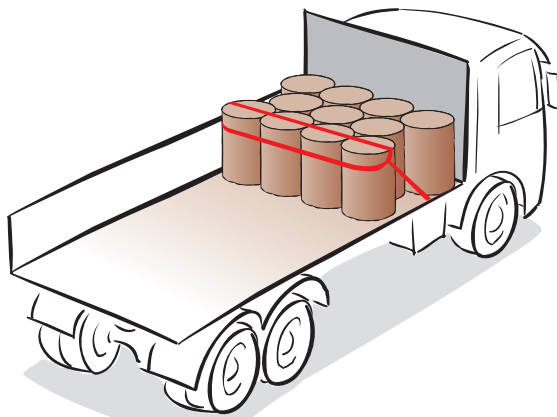

Barrels in large unit loads filling up the platform are blocked in the lower layer against parts of the vehicle. An eventual upper layer is blocked by thresholds and top-over lashings with edge beams/profiles in such a way that many barrels become a unit that cannot tip over.



## **Dangerous goods**

Securing dangerous goods according to ADR:



It hardly has to be mentioned that securing dangerous goods is especially important since the cargo has particularities that, more than other goods, can damage the environment. However, it is worth to stress to all those working in the transport industry that marking of goods may have imperfections and special knowledge is needed to understand that one commodity is more dangerous than another. Securing dangerous goods must meet the demands in a regulation called ADR.

In ADR 7.5.7.5 it is written *“The requirements of this paragraph are deemed to be complied with if the cargo is secured in accordance with standard “EN 12195-1:2010”.* This means that securing as described in this material meets the demands in ADR regulations.

## **Perishable goods**

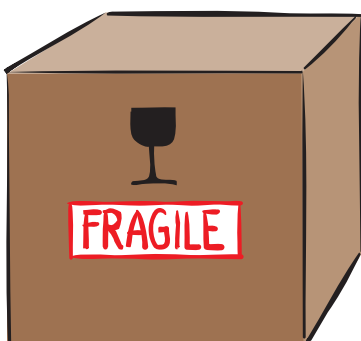

Speaking of methods to secure cargo, dangerous goods and perishable goods are more or less the same. But when some heavy goods get on top of the perishable, or when a lashing cuts through the package, the insurance cost will rise instead of the pollution. That is a poor consolation to the economy of the transport company and its reputation in the market.

A cautious but safe blocking in the box body or curtainside lorry is recommended for perishable goods. Lash with common sense.